



**WORLD'S BEST  
ALLOY BULLBARS**

**Strongest Built  
Australian Made  
Lifetime Warranty**

**NBRE21SY**



# **Fitting Guide & Owners Manual**

**Renault Master  
Pro MY20on**

76mm Nudge Bar  
VEHICLE FRONTAL PROTECTION SYSTEM (VFPS)  
FOR AIR BAG & ADR COMPLIANT VEHICLES



**S**  
**SUPERCARS  
OFFICIAL BULLBAR  
OF SUPERCARS**

# Index

---

## **Pages 3-5**

ECB's Benefits  
Product Care

## **Pages 6-7**

Stage 1 - Vehicle preparation  
Stages 2 to 3 - Remove grille  
Stage 4 - Remove bumper cover  
Stage 5 - Remove wind deflectors  
Stage 6 - Fit Steel mounting brackets

## **Pages 8-9**

Stage 7 - Lower grille trim  
Stage 8 - Air deflector trim and refit  
Stage 9 - Bumper refittment  
Stage 10 - Nudge Bar Fittiment  
Stage 11 - Secure bumper

## **Pages 10-11**

Final Checks & Installation Kit  
Finished Product

## **Pages 12-13**

Warranty Registration  
Notes

# The Features of ECB

---

Rust Free

Unmatched  
Strength

Hi-Tensile Alloy

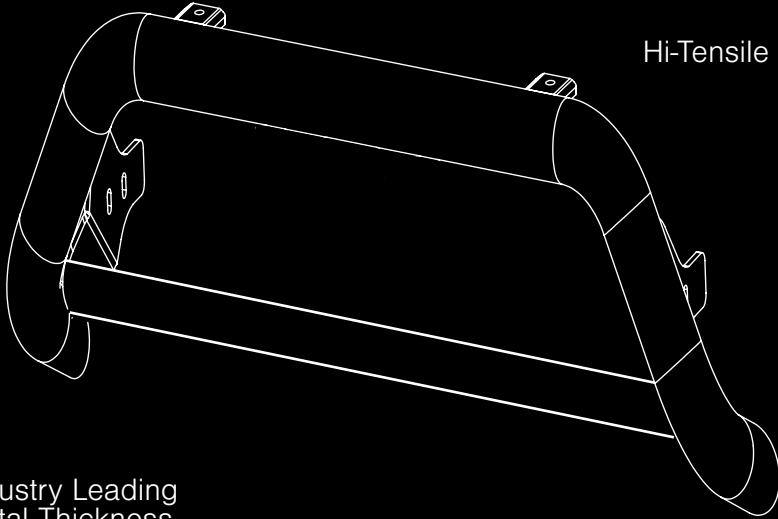

Industry Leading  
Metal Thickness

Fully Welded  
Construction

# ECB's Benefits

---

## **Built to Perform - Not to a Price**

ECB are proud to claim that their channels are not jigsaw puzzles that are bolted together, or even multiple sections welded together. Where any welding is required, it is done to the highest standards by qualified welders, not machines.

## **Anti-Corrosive Nature of Alloy**

The composition of ECB's alloy has a very high resistance to corrosion. Rust not only looks unappealing but greatly reduces the strength of the metal. Rust can and will weaken the structural integrity of a steel bullbar effectively rendering it useless over time.

## **Australian Made**

Established in 1971, we utilise over 46 years of experience designing, engineering and building products in Australia to suit Australian conditions. We can ensure the best quality controls and help support the local economy and employ over 90 proud Australians.

## **Weight Saving Benefits**

An ECB alloy bullbar is typically half the weight of a steel bullbar. Unnecessary suspension upgrades are not required. The reduced weight also contributes to increased fuel economy and less wear and tear on tyres, suspension and braking components.

## **Welds That Work**

ECB uses only the strongest welds and welding techniques to ensure every product is as structurally sound as possible. MIG (Metal Inert Gas) welding techniques are employed ensuring the welds are as thick as the thickest section of alloy's being joined together.

## **Lifetime Warranty**

ECB provide a lifetime warranty and consumer guarantee on all of our manufactured products. This guarantee highlights the confidence in our ability and provides complete peace of mind for your purchase for the lifetime you own your vehicle.

# Product Care

---

## Polished Products

Being a premium mirror polished finish, regular maintenance will be required to keep that iconic ECB shine. We recommend using our own brand of Aluminium Polish. This formula has been tried and tested and in our opinion is the world's best standard.

**Directions:** Apply a small quantity of Aluminium Polish to a clean soft cloth and rub the metal surface. The longer the rubbing the brighter the surface becomes. Wipe off Aluminium Polish with clean soft cloth. Also suitable for motorised buffing machines. **Note: There are more specific details on the polish bottle. Please read before use.**

## Powdercoated Products

Our powdercoated finishes are very low maintenance. Infact there is actually very little you will ever need to do for this product. Just clean it as you would your car and it will stay looking good as new.

## ECB Aluminium Polish

When you're looking for that showroom finish look for your polished automotive products, you can depend on the no compromise quality of East Coast Bullbars Aluminium Polish. This specifically designed product is the best polish available and we guarantee that this \$#!+ works. With over 40 years of manufacturing polished alloy products we have trialed a large range of different polishes on the market and believe without a doubt that nothing beats the finish quality of East Coast Bullbars Aluminium Polish.

East Coast Bullbars Aluminium Polish is excellent for use by hand and is ideal for polished bullbars, nudge bar and stainless steel products. This polish will clean, polish and protect your product from the elements whilst bringing your products back to that showroom finish look.



# NBRE21SY

## Stage 1

- Test drive vehicle to ensure all driver assists are correctly working and to gauge effectiveness. Park on a flat level surface.
- Apply parking brake and lift bonnet.
- Unwrap ECB Protection bar and disconnect mounts. Discard bolts.
- Ensure these instructions are left with the vehicle owner / operator.



## Stage 2

- Remove four (4) T30 Torx head screws from top of grille.
- Release bonnet cable from bonnet release latch.



**CAUTION:** Do not close bonnet with bonnet latch disconnected

## Stage 3

- Pull grille up and forward to remove.



# RENAULT MASTER PRO MY20on

## Stage 4

- Removing six (6) T30 Torx head screws from top of bumper, three (3) T30 Torx head screws from Inner wheel arch (per side) and three (3) T30 Torx head screws from underside of bumper.
- Remove bumper cover.

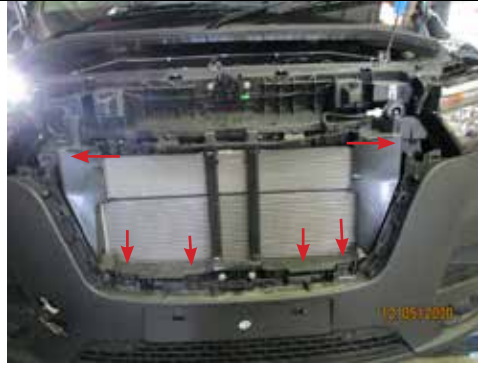

## Stage 5

- Remove lower wind deflectors and retain for refitment.
- Remove two (2) lower 16mm head bolts from bumper support (per side).

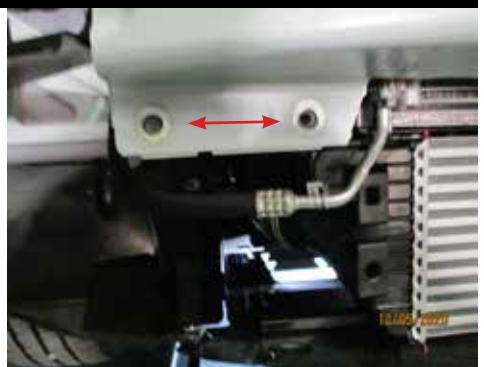

## Stage 6

- On front of bumper support secure ECB steel mounting brackets (supplied) to chassis rail front using two (2) M10 x 1.5 x 35mm bolt, flat washer and spring washer (supplied)
- Feed M10 x 1.5 nut and 50 x 50 x 6mm washer plate on 300mm wire (supplied) through bumper support and secure using M10 x 1.5 x 35 bolts, spring washer and flat washer (supplied).
- Align mounts and tighten all bolts.



# NBRE21SY

## Stage 7

- Carefully cut out template supplied to trim lower grille for steel mounting brackets to protrude. Check scale as some printers vary.
- Tape area to avoid any damage.
- Double check all markings before cutting.
- Carefully cut out required area for steel mounting brackets to protrude. This cut will be seen so ensure it is neatly done.



## Stage 8

- Trim air deflectors to suit steel mounting brackets.
- Refit air deflectors to vehicle.



## Stage 9

- Replace bumper in reverse of steps 2 to 4.
- Do not secure to underbody guard at this stage.





# RENAULT MASTER PRO MY20on

## Stage 10

- Fit protection bar to vehicle with M10 x 1.5 x 40mm bolts, flat washers, spring washers and nuts (supplied).
- To access rear bolt, go through bottom of bumper on underside of vehicle.
- Align protection bar with vehicle and **tighten all bolts.**



## Stage 11

- Secure under side of bumper.



# Final Checks & Installation Kit

---

## Ensure Number Plate is Clearly Visible

Note: When fitting/refitting the licence plate to the vehicle, ensure there is no obstruction to licence plate vision in accordance with local authorities. If required relocate licence plate to an alternate location.

## Further VFPS Notes

1. Do not attach VFPS to the vehicle using anchorages not intended for this purpose (e.g. engine mounting bolts).
2. Do not use this product for any vehicle make or model, other than those specified by the VFPS manufacturer.
3. Do not remove the plaque or label from the VFPS.
4. Do not modify the structure of the VFPS in any way.
5. No accessory or fitment should project forward of the VFPS forward profile.
6. **Ensure these instructions are left with the vehicle owner and/or operator.**

## Important Information

Periodically check bolts and nuts for correct tightness, especially if traveling on rough roads.

## Installation Kit

1 - Pair steel mounting brackets	10 - M10 spring washer
6 - M10 x 1.5 x 35mm bolts	4 - M10 x 1.5 nuts
4 - M10 x 1.5 x 40mm bolts	2 - M10 x 1.5 nuts & 50 x 50 x 6mm washer plate on 300mm wire
14 - M10 flat washers	

# Finished Product

---



# Warranty Registration

---

## Contact Details

Name: \_\_\_\_\_

Address: \_\_\_\_\_

\_\_\_\_\_

Product: **NBRE21SY** \_\_\_\_\_

Email: \_\_\_\_\_

Phone: \_\_\_\_\_

Work Order Number: \_\_\_\_\_

You can find this on the silver label  
of your ECB product.

By submitting this registration you automatically subscribe to ECB's mail outs. You  
can unsubscribe at any time.

## Register Online

For online registration please go online to [www.ecb.com.au/warranty-registration](http://www.ecb.com.au/warranty-registration)  
If you have any questions please contact our national office on 1800 069 145 or  
[www.ecb.com.au](http://www.ecb.com.au).

## Or Post To

PO Box 122 Margate QLD 4019



**PN: NBRE21SY**  
**Please post to: PO Box 122,**  
**Margate QLD 4019**





REPLACES: N/A  
REVISED: 08.06.20

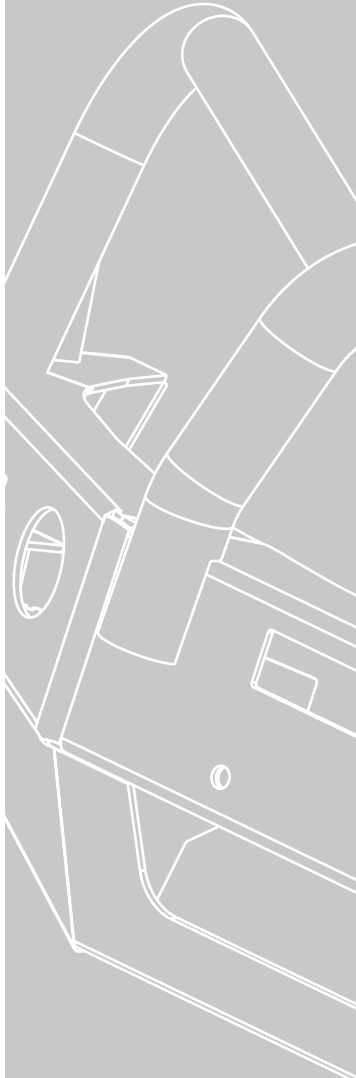

1800 069 145  
[www.ecb.com.au](http://www.ecb.com.au)

# **Strongest Built Australian Made Lifetime Warranty**

29 Snook St, Clontarf QLD 4019  
PO Box 122, Margate QLD 4019